

NOTE:-
 Enclosures can be Factory Modified (Milling, Drilling, Printing etc)
 Contact www.Pincore.in for Quotes
 Solid models of this enclosure available in STL or IIGES

PRODUCT ID	ORDER NO.
PRODUCT NAME	
TYPE OF PRODUCT	
MATERIAL	
FINISHING	
ACCESSORIES	
www.Pincore.in	

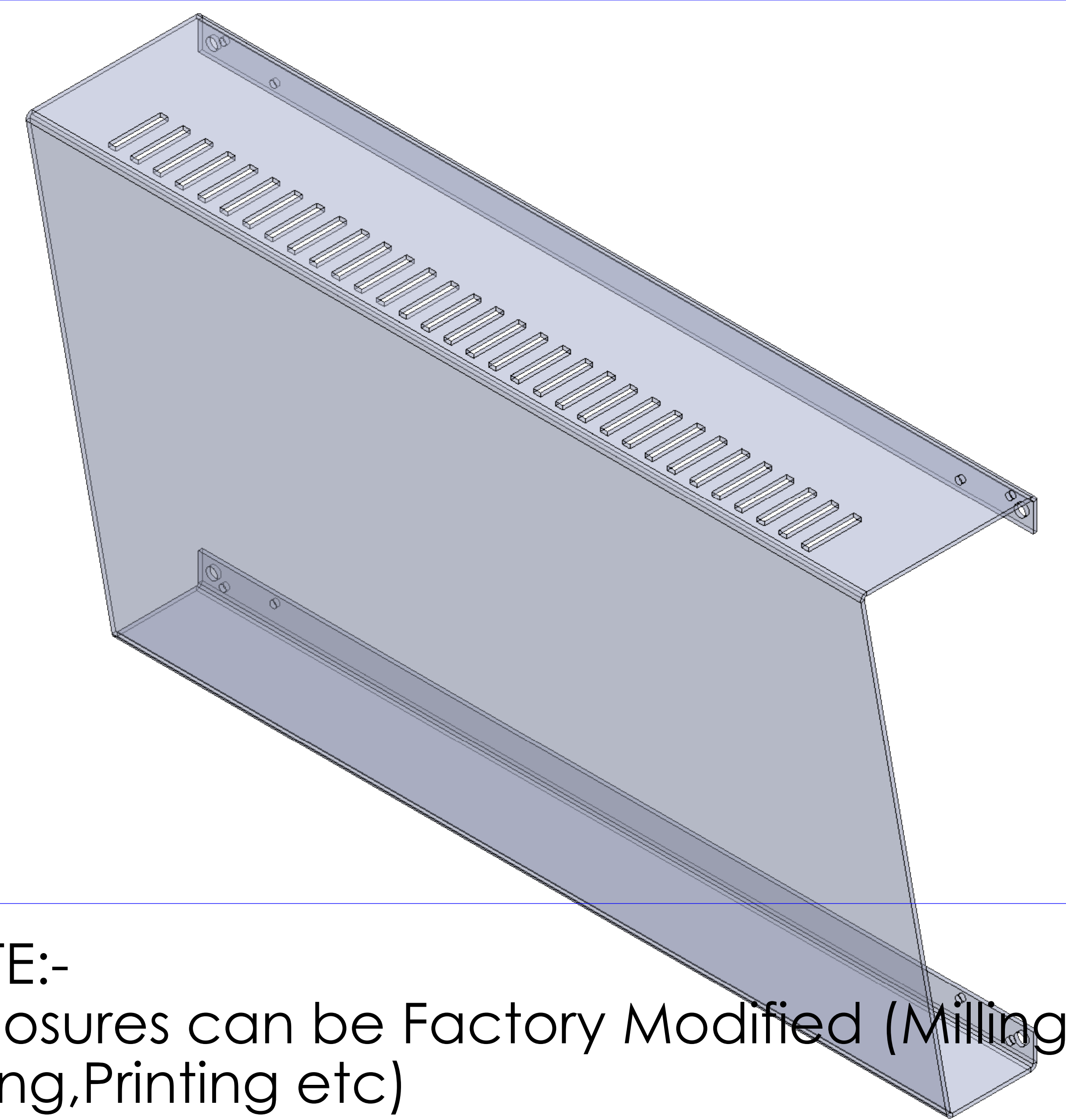

pincore technologies
india pvt. ltd.

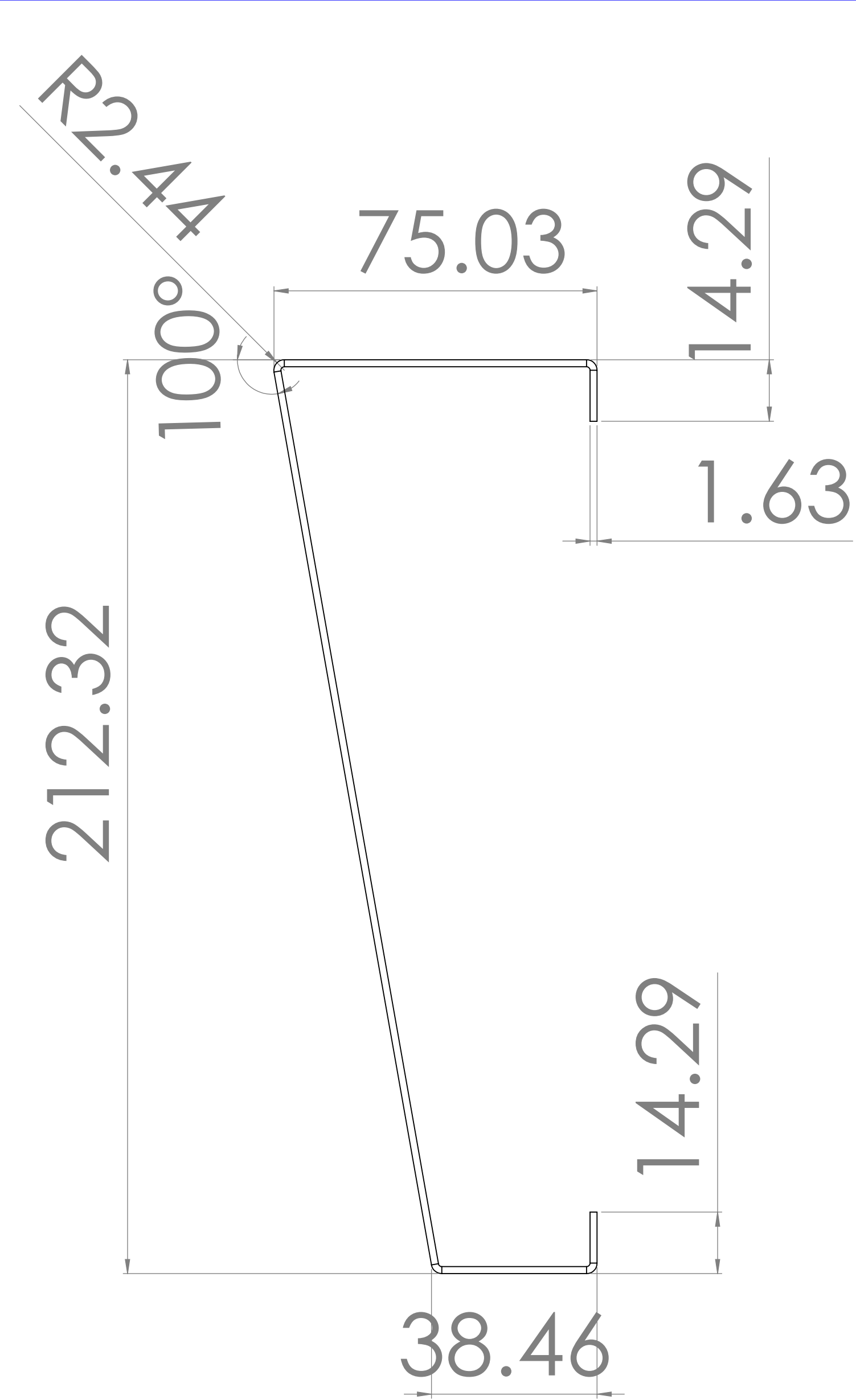
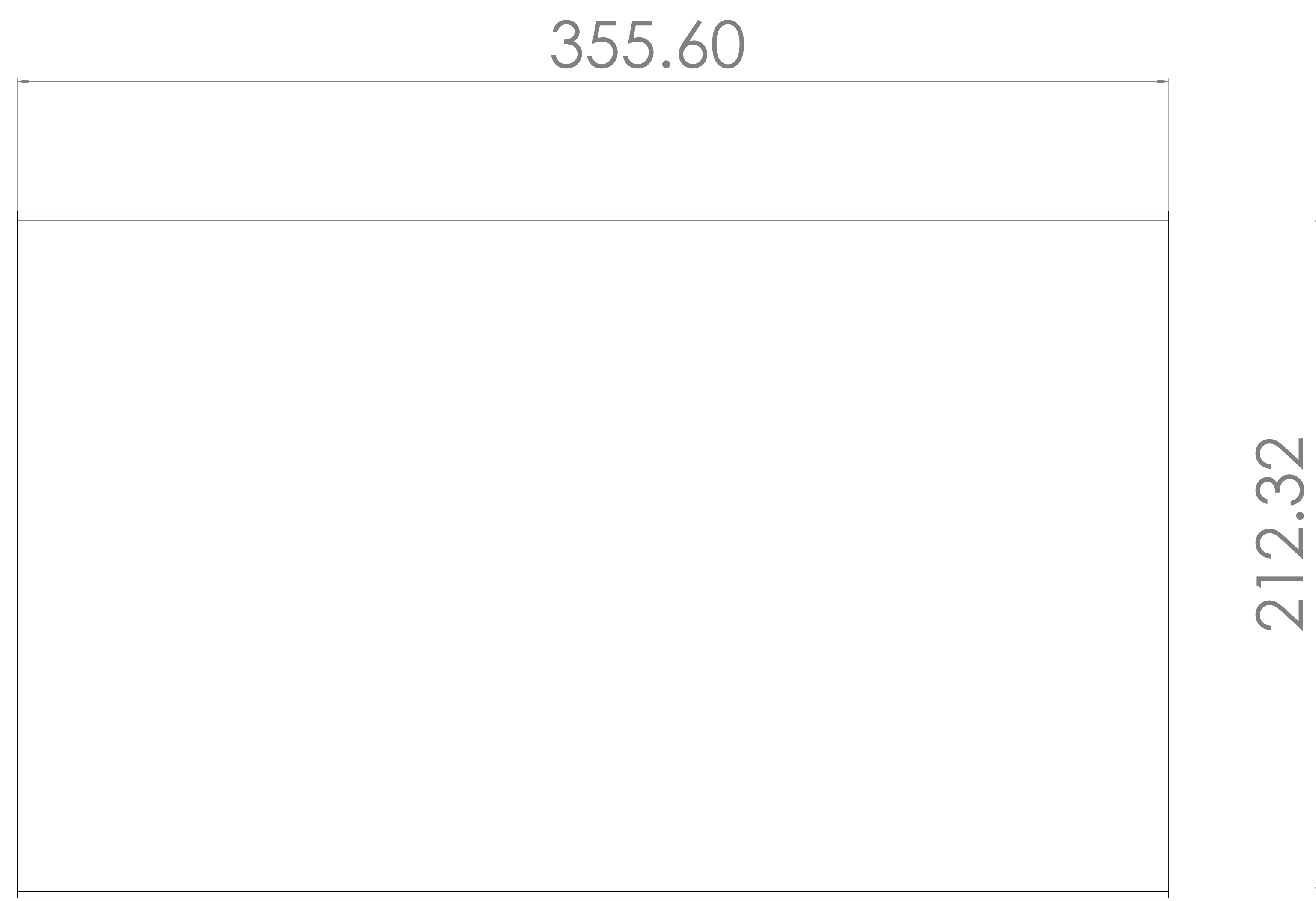

NOTE:-
 Enclosures can be Factory Modified (Milling, Drilling, Printing etc)
 Contact www.Pincore.in for Quotes
 Solid models of this enclosure available in STL or IIGES

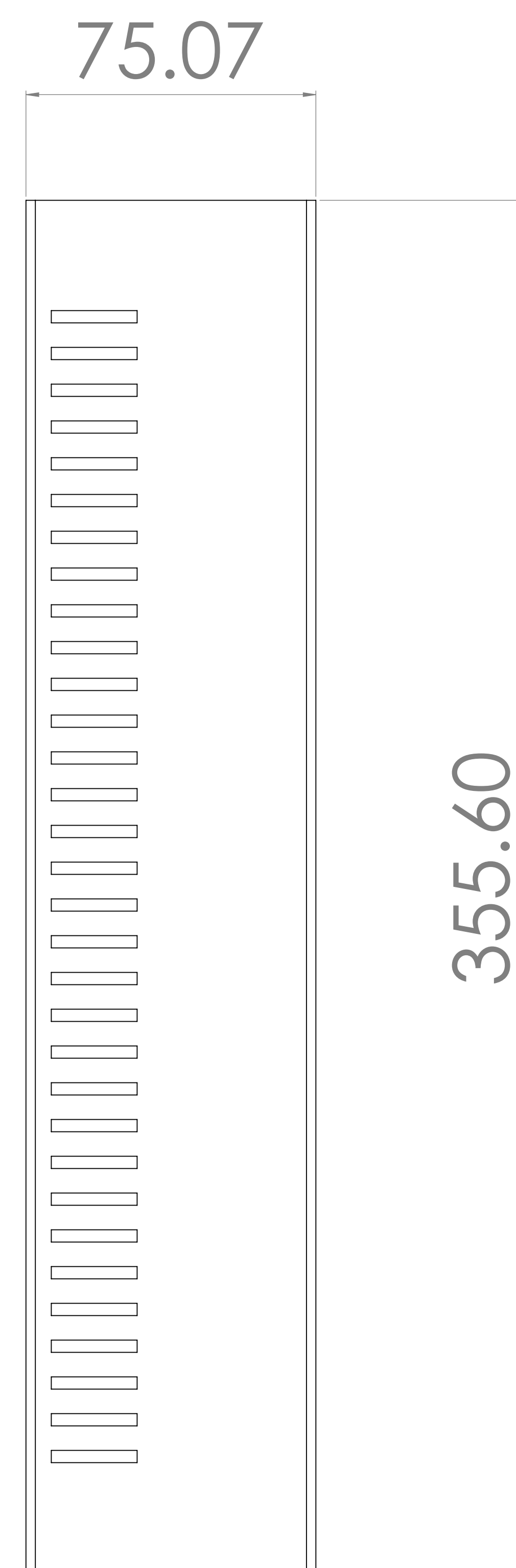
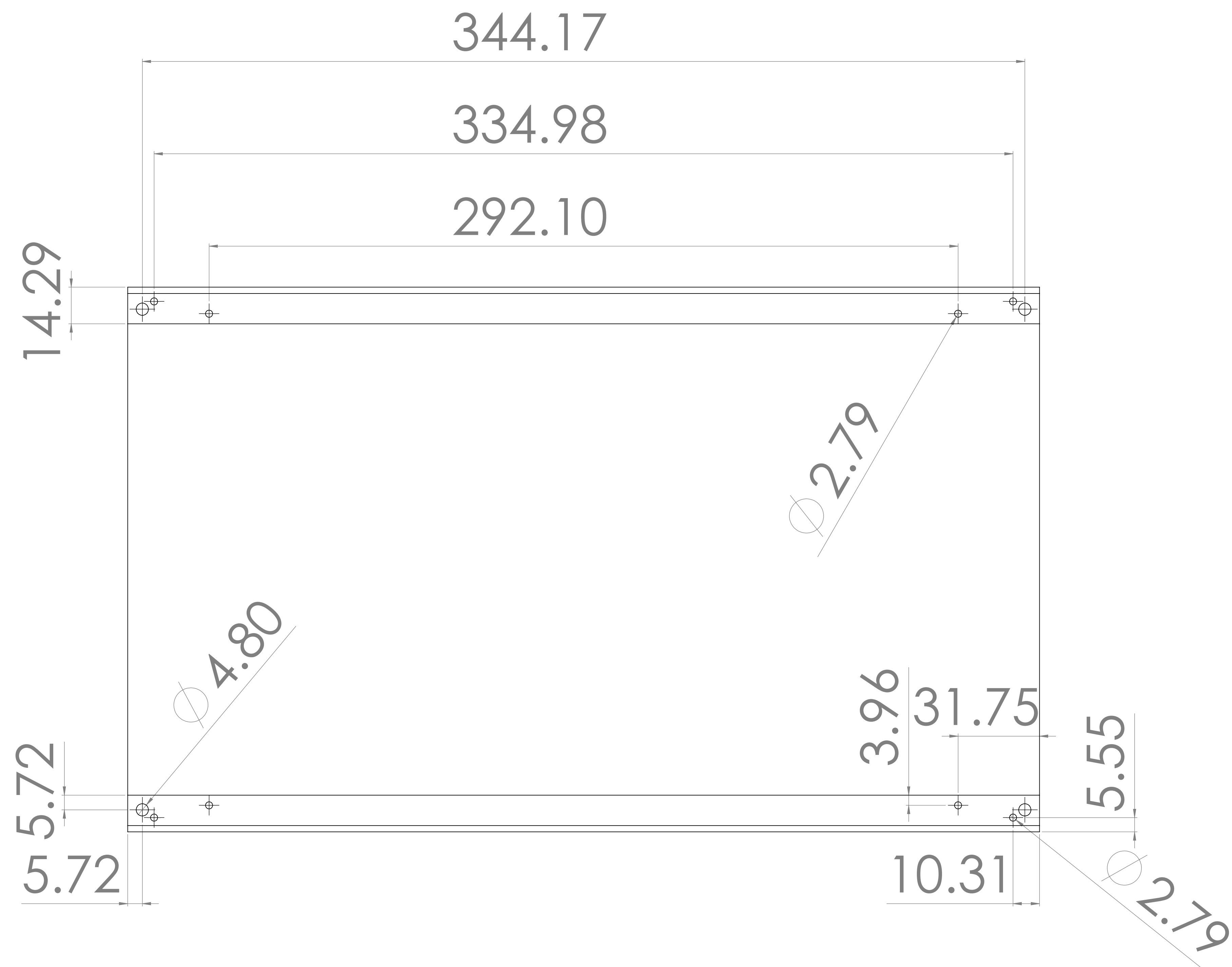

PRODUCT ID	ORDER NO.
PRODUCT NAME	
TYPE OF PRODUCT	
MATERIAL	
FINISHING	
ACCESSORIES	
www.Pincore.in	



pincore technologies
india pvt. ltd.